



Rack-Mammut®
Handlauf Einzelplanke
Single bumper pedestrian barrier



Montageanleitung
Assembly instruction

Benötigte Werkzeuge

Required tools

Standard Version (2 m)

Standard version (2 m)



Bestandteile

Components

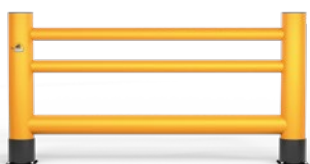
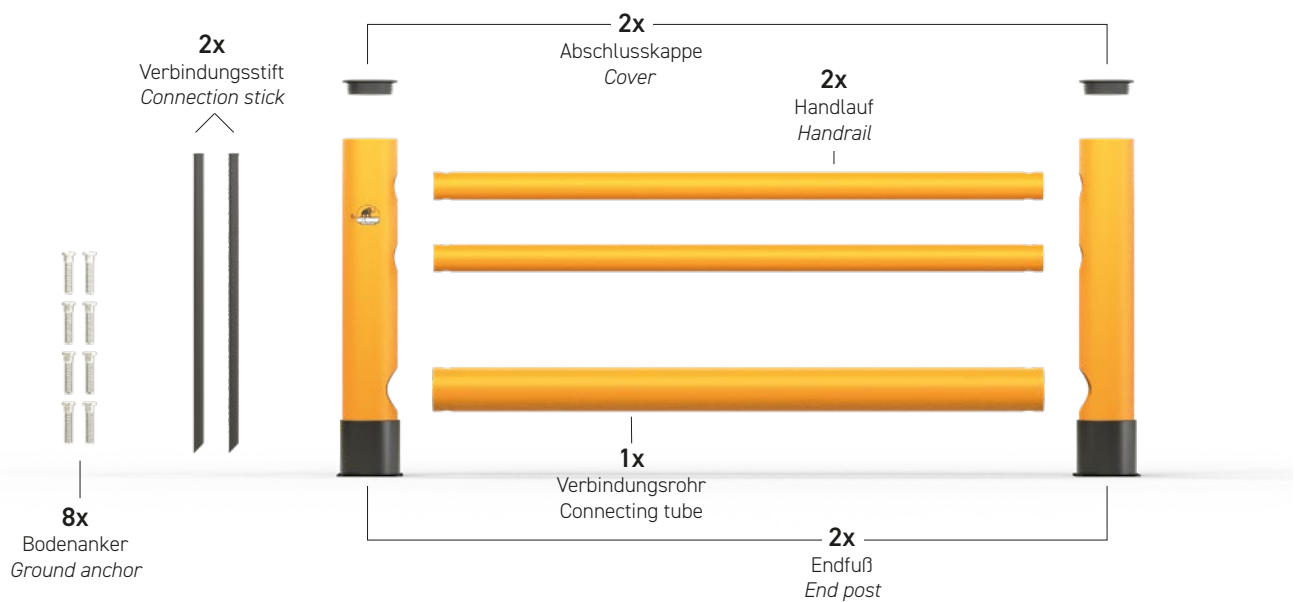

Standardausführung (2 m)
Standard version (2 m)



! *erweiterte Version (6 m)
extended version (6 m)

Technische Daten

Technical data

- ▶ Höhe/Height: 1100 mm
- ▶ Poller/Bollard: \varnothing 180 mm
- ▶ Handlauf/Handrail: \varnothing 90 mm
- ▶ Verbindungsrohr/Connecting tube: \varnothing 144 mm
- ▶ Bodenplatte (BxLxH)/Base plate (WxLxH): 210 mm x 210 mm x 12 mm
- ▶ Standardlänge/Standard length: 2 m (Fußmitte zu Fußmitte/Centre of foot to centre of foot)



Das Produkt kann auch auf individuelle Maße angepasst werden.

The product can also be customised to individual dimensions.

Montage/Assembly

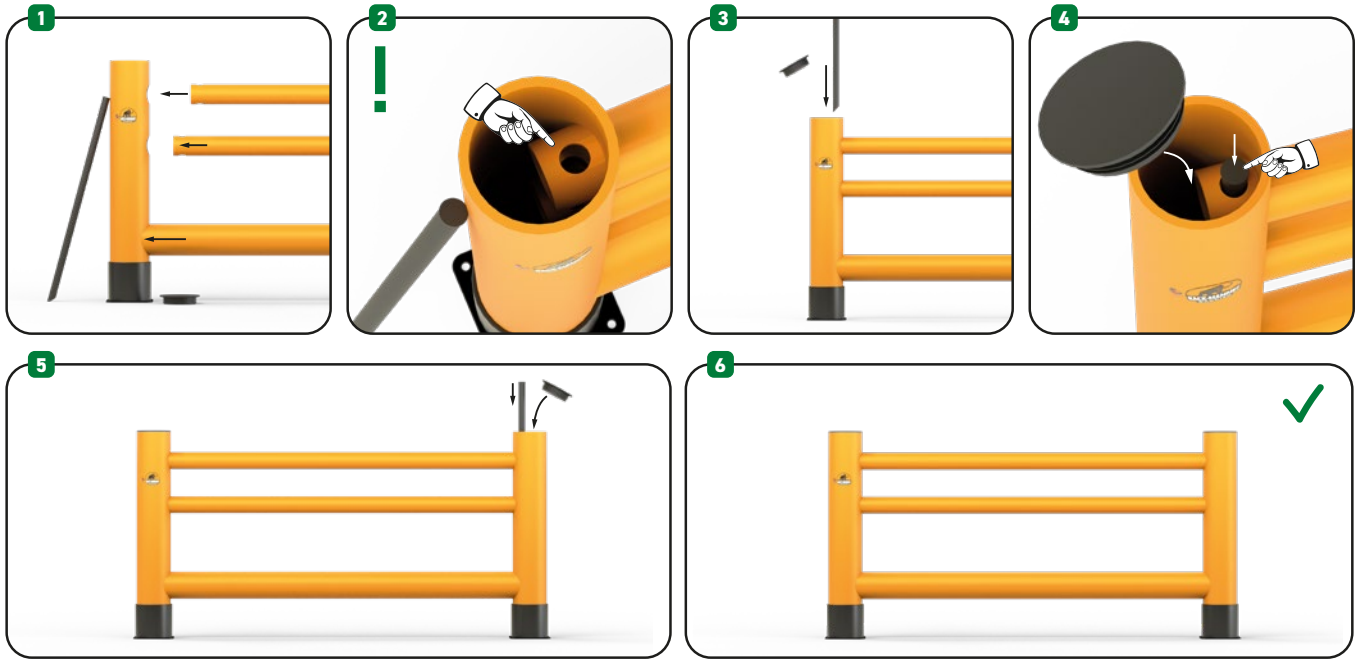

Montagedetails/Assembly details

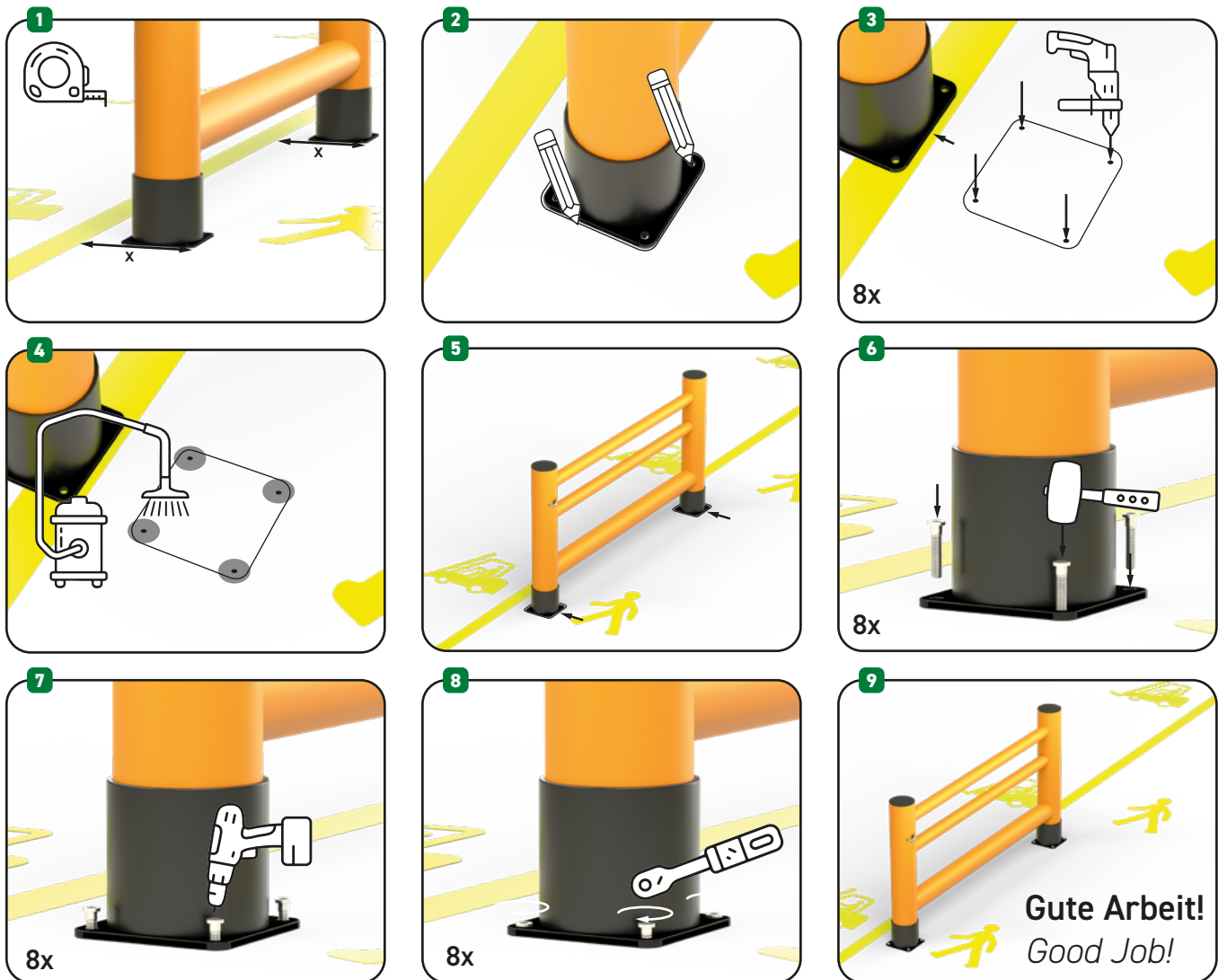

Benötigte Werkzeuge

Required tools

Erweiterte Version (6 m)

Extended version (6 m)



Bestandteile

Components

4x
Abschlusskappe
Cover



6x
Handlauf
Handrail

16x
Bodenanker
Ground anchor

6x
Verbindungsstift
Connection stick

2x
Endfuß
End post

2x
Mittelfuß
Mid post

3x
Verbindungsrohr
Connecting tube



Standardausführung (2 m)
Standard version (2 m)

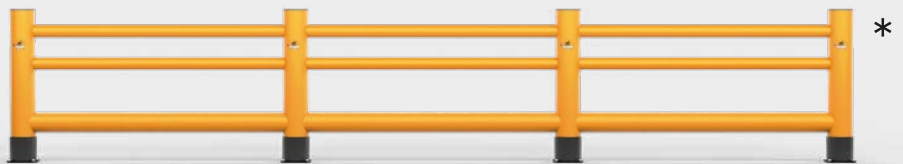

! *erweiterte Version (6 m)
extended version (6 m)

Technische Daten

Technical data

- ▶ Höhe/Height: 1100 mm
- ▶ Poller/Bollard: \varnothing 180 mm
- ▶ Handlauf/Handrail: \varnothing 90 mm
- ▶ Verbindungsrohr/Connecting tube: \varnothing 144 mm
- ▶ Bodenplatte (BxLxH)/Base plate (WxLxH): 210 mm x 210 mm x 12 mm
- ▶ Ausführung/Version: 6 m (Fußmitte zu Fußmitte/Centre of foot to centre of foot)



Das Produkt kann auch auf individuelle Maße angepasst werden.
The product can also be customised to individual dimensions.

Montage Assembly

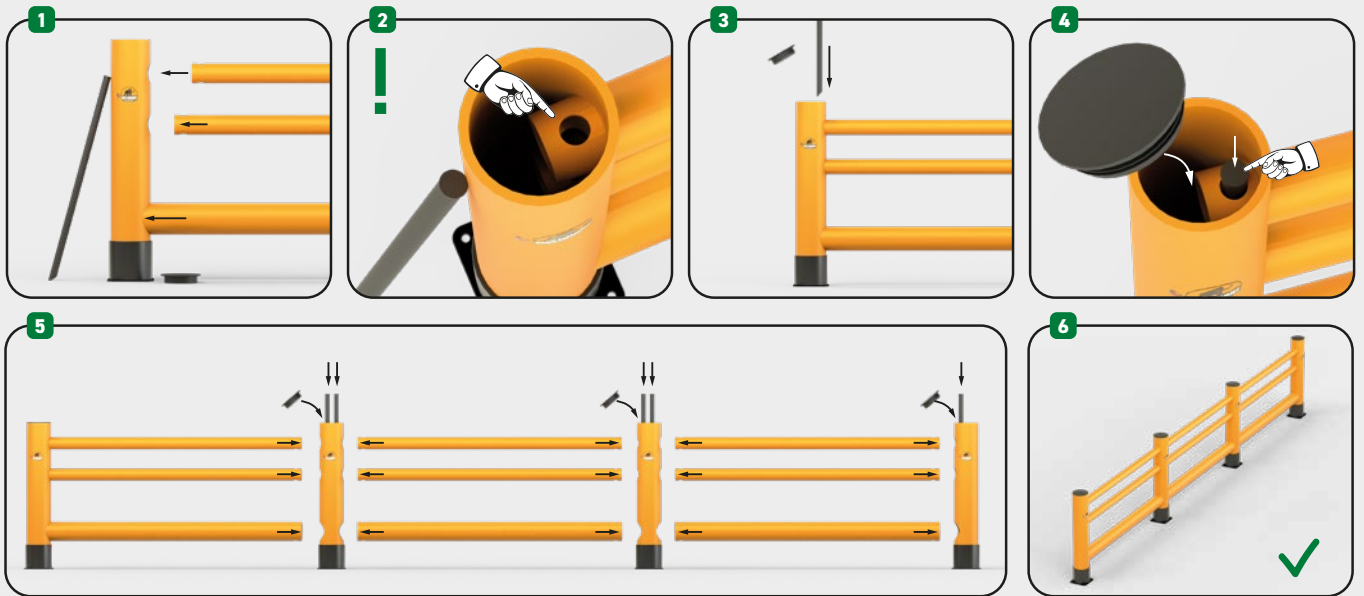

Montagedetails/Assembly details

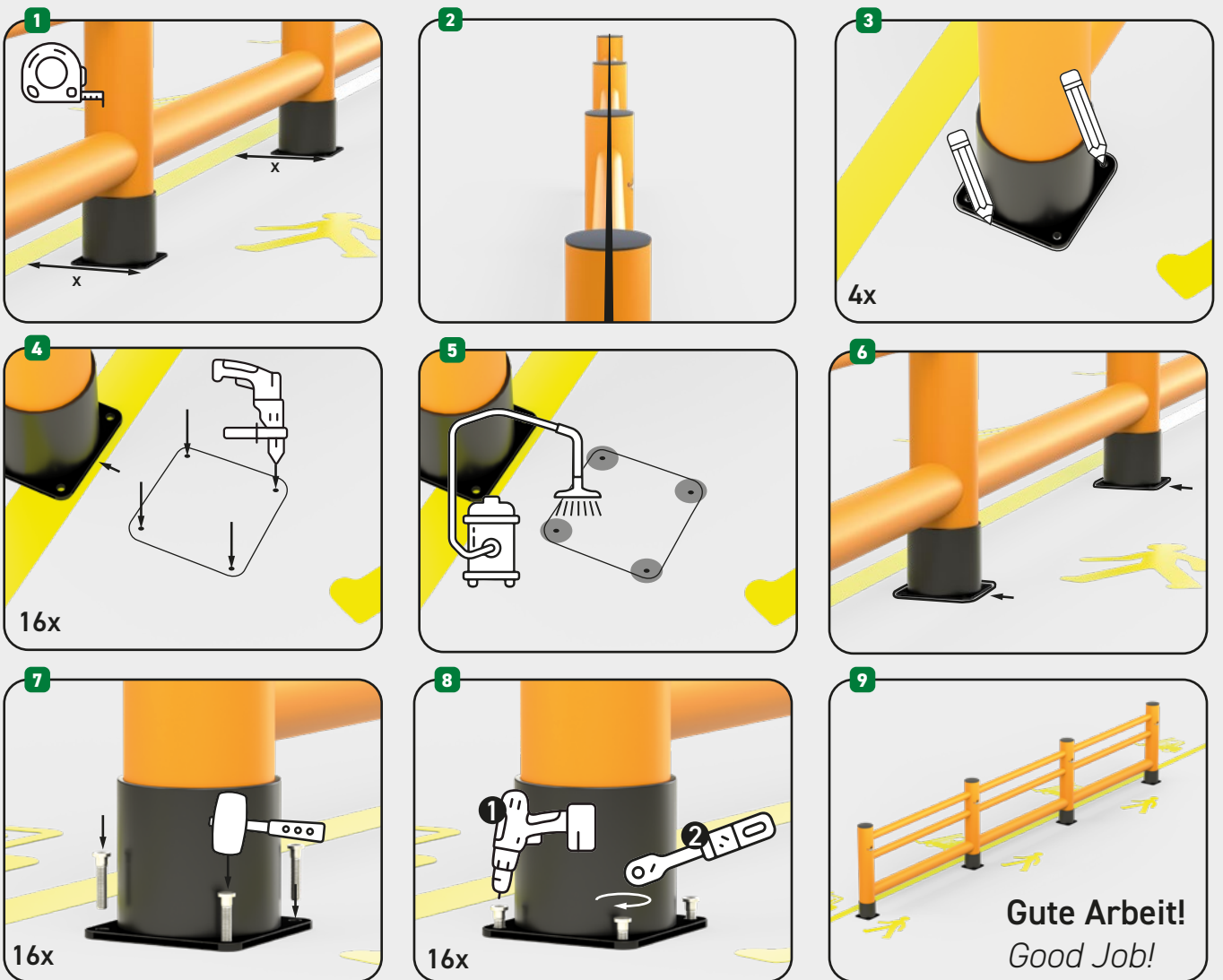



Auszug aus dem Rack-Mammut® Sortiment
Part of the Rack-Mammut® assortment



Rack-Mammut®
Regalendschutz Einzelplanke
Rack end single rail barrier



Rack-Mammut®
Regalendschutz Doppelplanke
Rack end double rail barrier



Rack-Mammut®
Rammschutzbarriere Einzelplanke
Single bumper barrier



Rack-Mammut®
Rammschutzbarriere Doppelplanke
Double bumper barrier

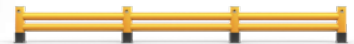

Rack-Mammut®
Handlauf
Pedestrian handrail barrier



Rack-Mammut®
Handlauf Flex
Pedestrian handrail barrier



Rack-Mammut®
Handlauf Einzelplanke
Single bumper pedestrian barrier



Rack-Mammut®
Handlauf Doppelplanke
Double bumper pedestrian barrier



Rack-Mammut®
Rammschutz-Poller
Bollard



Rack-Mammut®
Rammschutz-Poller Strong
Bollard Strong



Rack-Mammut®
Schwingtür
Swing gate



Rack-Mammut®
Bodenbarriere
Floor rail barrier



Rack-Mammut®
Höhenbegrenzer Strong
Height limiter



Rack-Mammut®
Alarm Höhenbegrenzer
Alarm height barrier

