



**Rack-Mammut®**  
**Handlauf Doppelplanke**  
*Double bumper pedestrian barrier*



---

**Montageanleitung**  
*Assembly instruction*

## Benötigte Werkzeuge

Required tools

## Standard Version (2 m)

Standard version (2 m)



## Bestandteile

Components

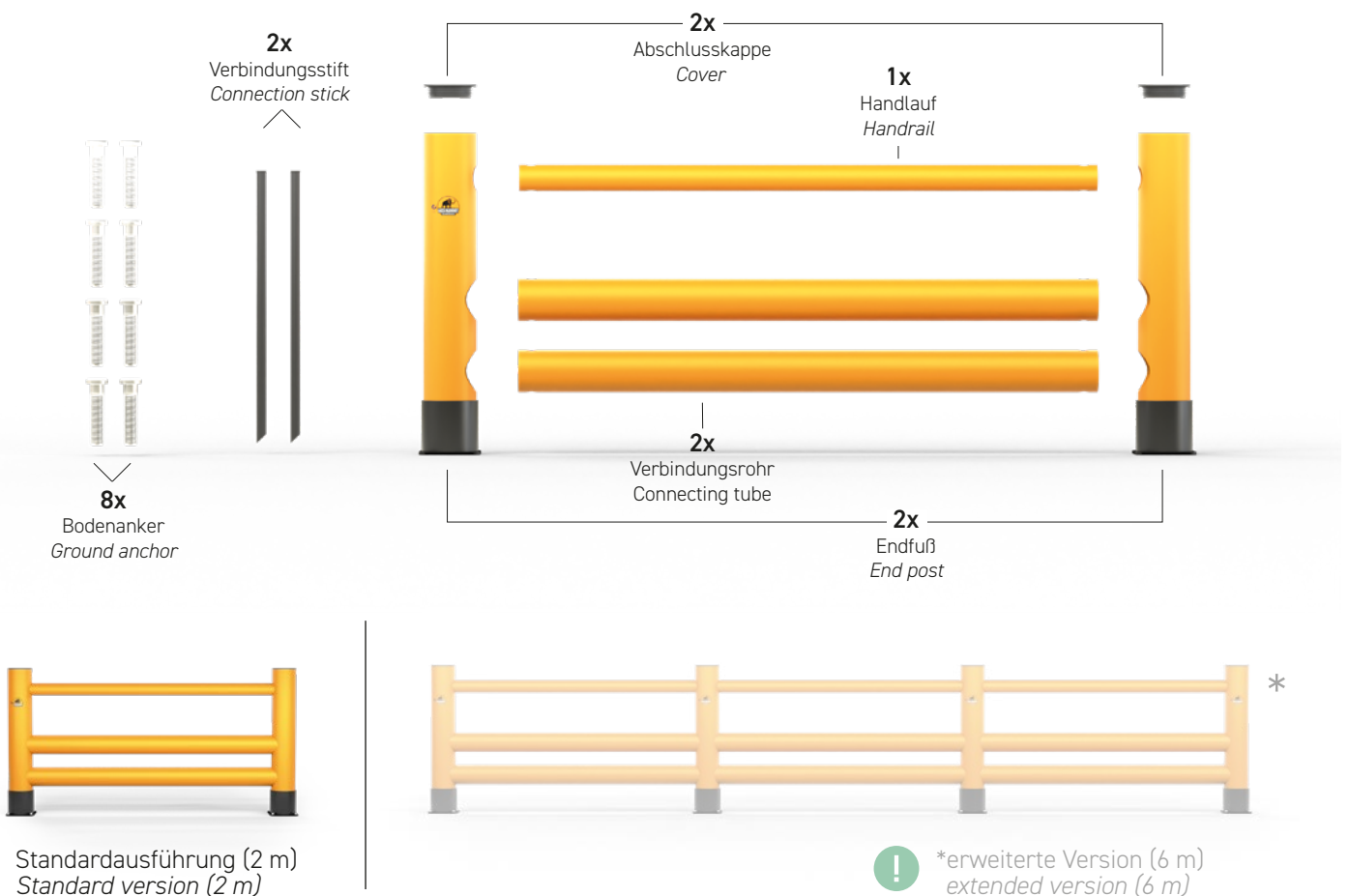

## Technische Daten

Technical data

- ▶ Höhe/Height: 1100 mm
- ▶ Poller/Bollard:  $\varnothing$  180 mm
- ▶ Handlauf/Handrail:  $\varnothing$  90 mm
- ▶ Verbindungsrohr/Connecting tube:  $\varnothing$  144 mm
- ▶ Bodenplatte (BxLxH)/Base plate (WxLxH): 210 mm x 210 mm x 12 mm
- ▶ Standardlänge/Standard length: 2 m (Fußmitte zu Fußmitte/Centre of foot to centre of foot)



Das Produkt kann auch auf individuelle Maße angepasst werden.

The product can also be customised to individual dimensions.

## Montage/Assembly

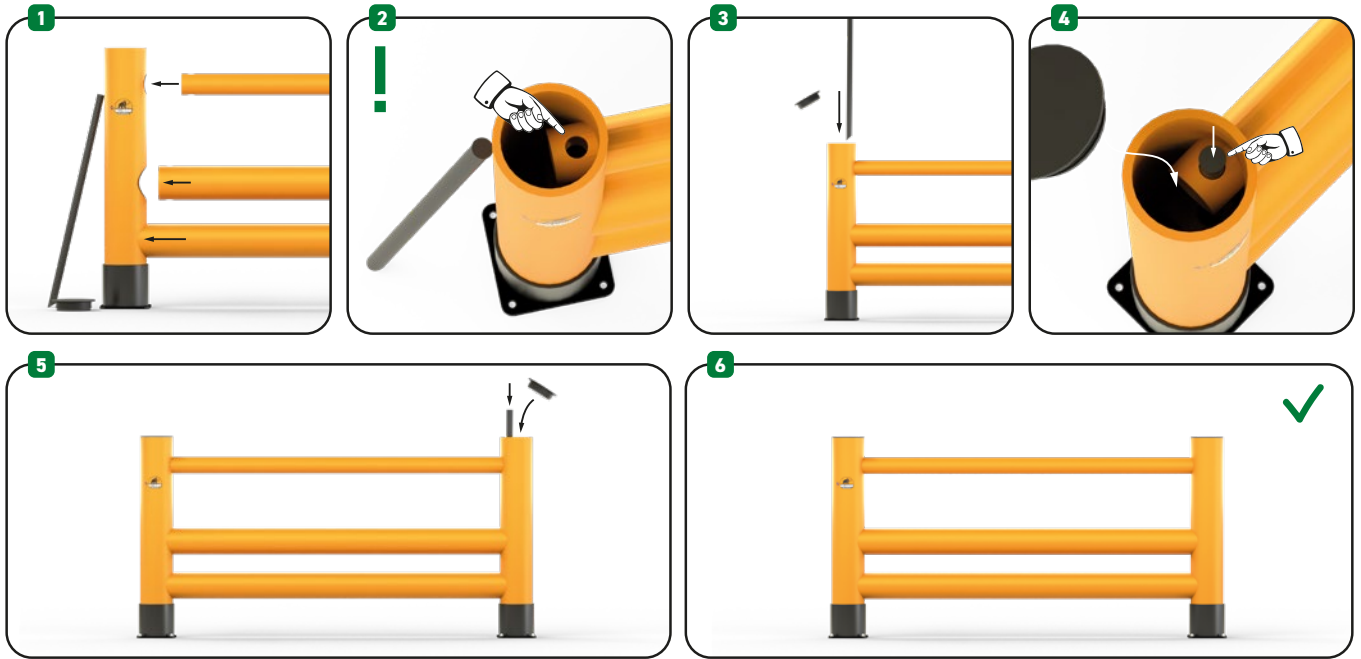

## Montagedetails/Assembly details

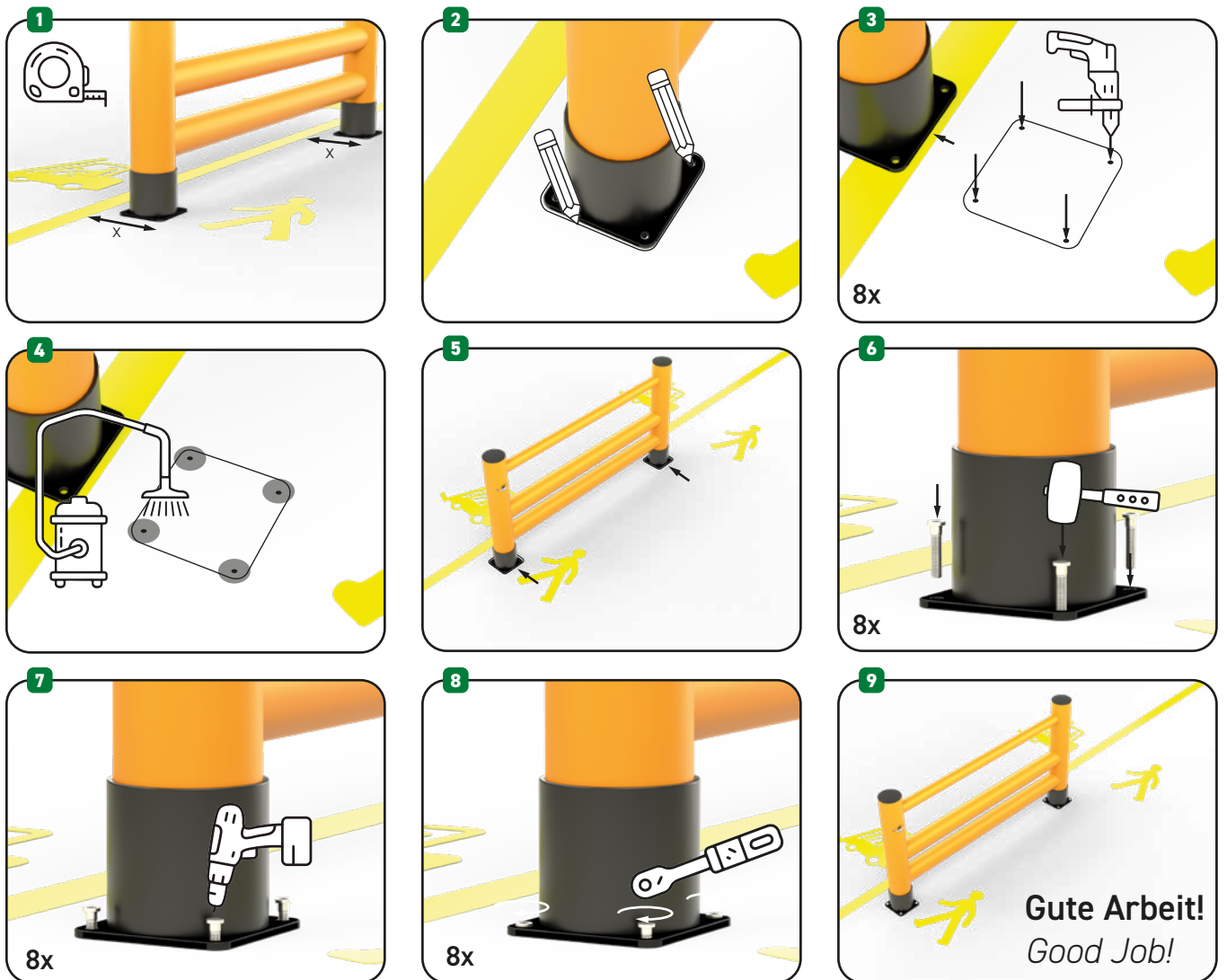

## Benötigte Werkzeuge

Required tools

## Erweiterte Version (6 m)

Extended version (6 m)



## Bestandteile

Components

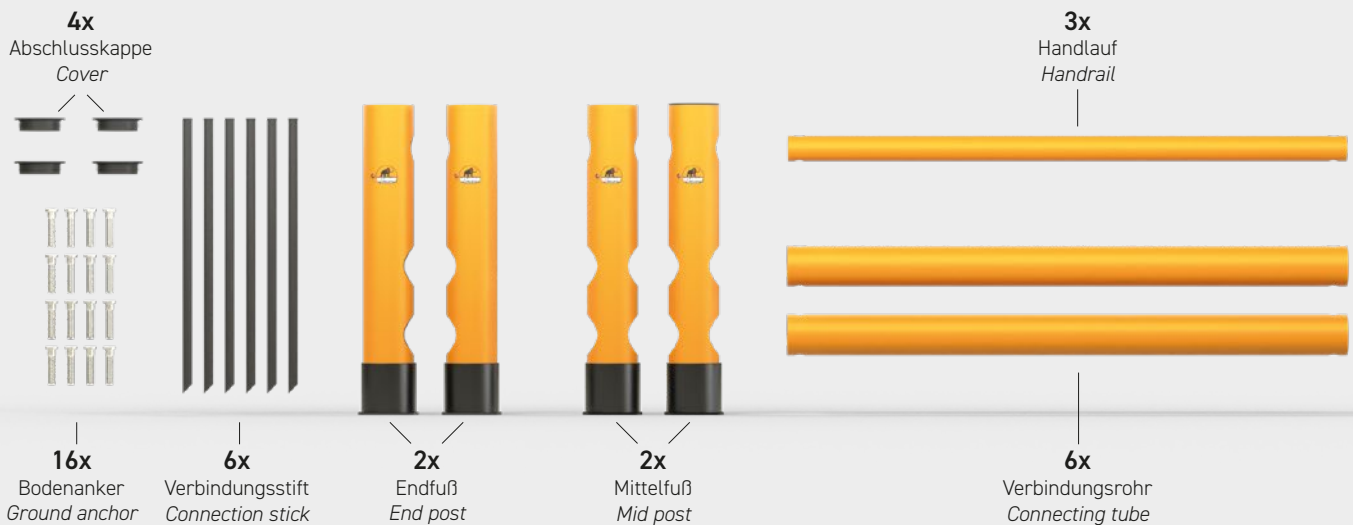

Standardausführung (2 m)  
Standard version (2 m)



! \*erweiterte Version (6 m)  
extended version (6 m)

## Technische Daten

Technical data

- ▶ Höhe/Height: 1100 mm
- ▶ Poller/Bollard:  $\varnothing$  180 mm
- ▶ Handlauf/Handrail:  $\varnothing$  90 mm
- ▶ Verbindungsrohr/Connecting tube:  $\varnothing$  144 mm
- ▶ Bodenplatte (BxLxH)/Base plate (WxLxH): 210 mm x 210 mm x 12 mm
- ▶ Ausführung/Version: 6 m (Fußmitte zu Fußmitte/Centre of foot to centre of foot)



Das Produkt kann auch auf individuelle Maße angepasst werden.  
The product can also be customised to individual dimensions.

# Montage Assembly

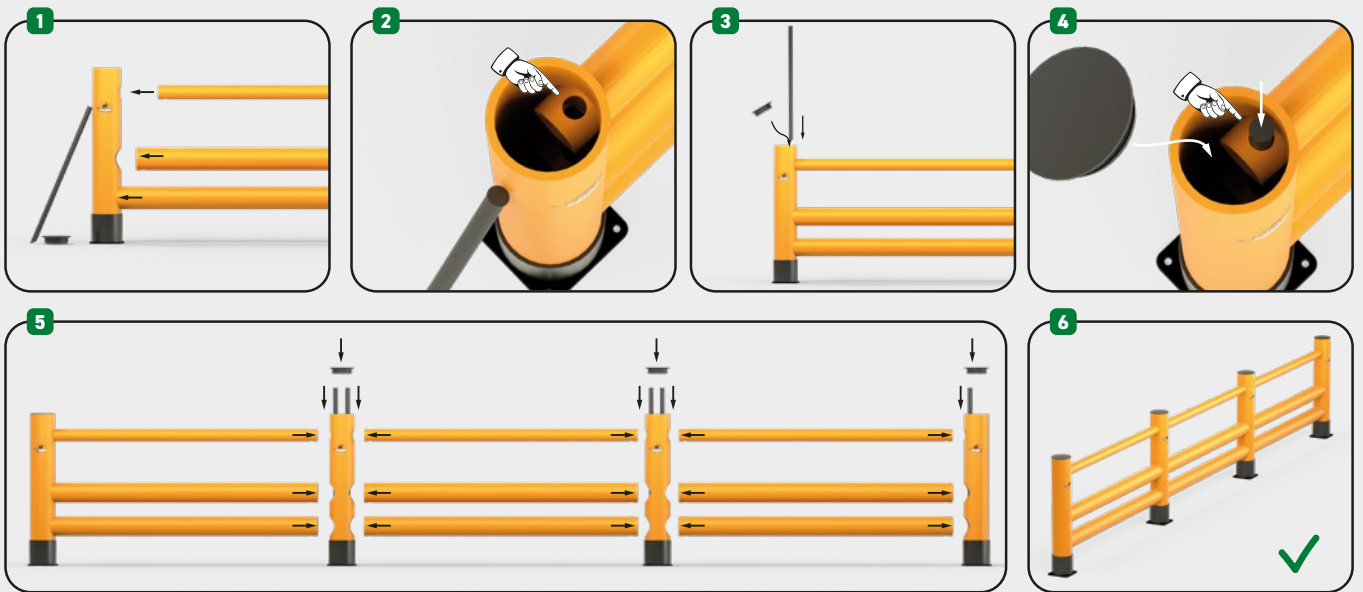

## Montagedetails/Assembly details

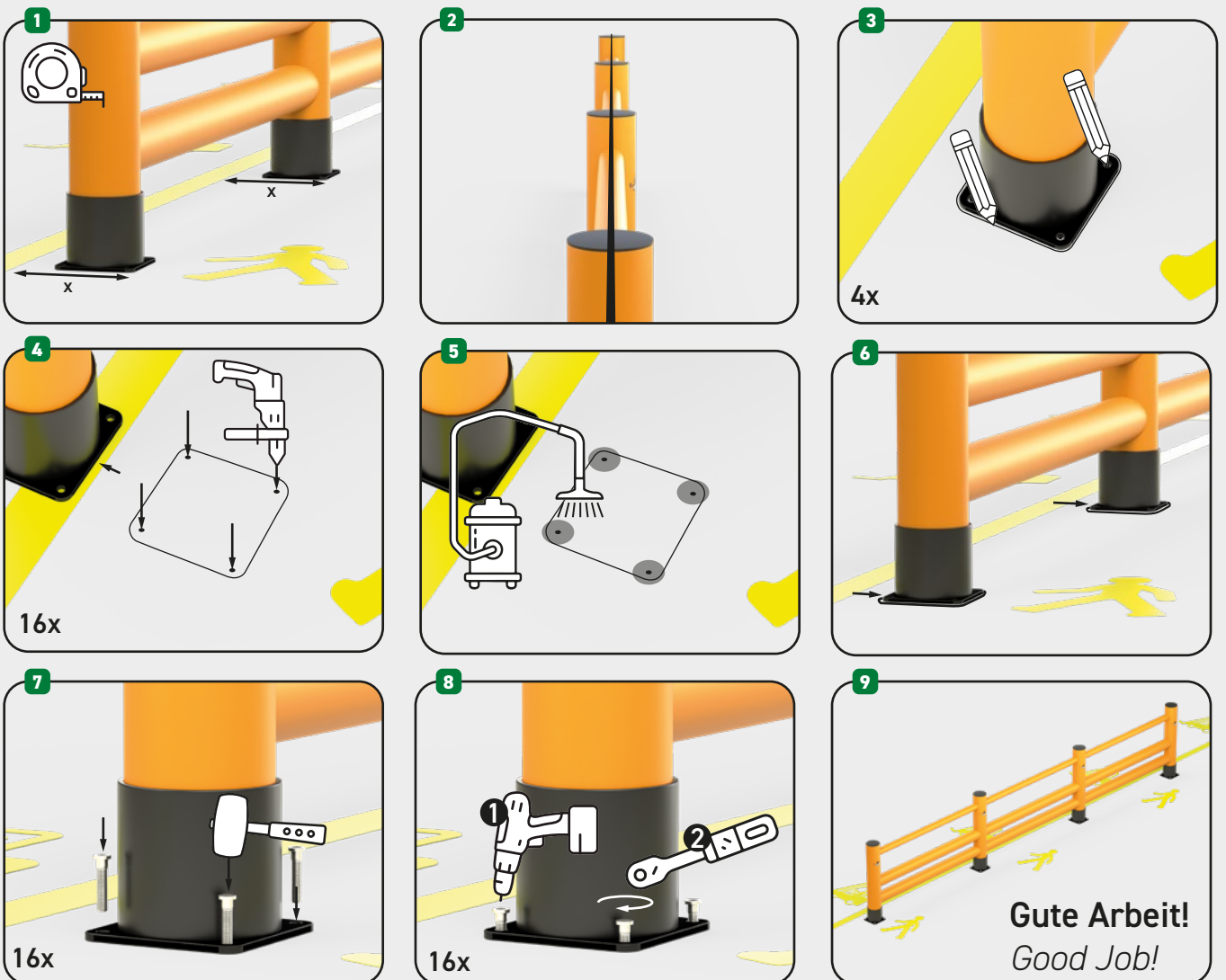



Auszug aus dem Rack-Mammut® Sortiment

Part of the Rack-Mammut® assortment



**Rack-Mammut®**  
**Regalendschutz Einzelplanke**  
*Rack end single rail barrier*



**Rack-Mammut®**  
**Regalendschutz Doppelplanke**  
*Rack end double rail barrier*



**Rack-Mammut®**  
**Rammschutzbarriere Einzelplanke**  
*Single bumper barrier*



**Rack-Mammut®**  
**Rammschutzbarriere Doppelplanke**  
*Double bumper barrier*

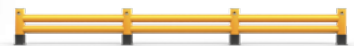

**Rack-Mammut®**  
**Handlauf**  
*Pedestrian handrail barrier*



**Rack-Mammut®**  
**Handlauf Flex**  
*Pedestrian handrail barrier*



**Rack-Mammut®**  
**Handlauf Einzelplanke**  
*Single bumper pedestrian barrier*



**Rack-Mammut®**  
**Handlauf Doppelplanke**  
*Double bumper pedestrian barrier*



**Rack-Mammut®**  
**Rammschutz-Poller**  
*Bollard*



**Rack-Mammut®**  
**Rammschutz-Poller Strong**  
*Bollard Strong*



**Rack-Mammut®**  
**Schwingtür**  
*Swing gate*



**Rack-Mammut®**  
**Bodenbarriere**  
*Floor rail barrier*



**Rack-Mammut®**  
**Höhenbegrenzer Strong**  
*Height limiter*



**Rack-Mammut®**  
**Alarm Höhenbegrenzer**  
*Alarm height barrier*

