

Technisches Datenblatt | Technical data sheet - AGE231734 / Pos.: 1

Allgemeine Daten general data			
Netzanschluss	power supply	380-415 / 3 / 50	V / ph / Hz
Netzabsicherung	main fuse	20	A
Steuerspannung	control voltage	24	VAC
Netzzuleitung	main supply cable	4G1.5	
Kettenspeicher	chain bag	Textil	
Netto Gesamtmasse ca.	weight	83	kg

Elektrokettenzug electric chain hoist			
Bauform	model	091/55	
Traglast	working load	1600	kg
Strangzahl	no.of load falls	1	
Anzahl Bremsen	no.of breaks	1	
Hubhöhe	lifting height	3,0	m
Hubgeschwindigkeit(en)	lifting speed(s)	8,0 / 2,00	m/min
Triebwerksgruppe	duty group	2m/M5	FEM/ISO
Einschaltdauer	duty rate	60 / 25	%
Schaltungen/Stunde	starts per hour	240	S/h
IP Schutzart	IP protection class	IP 55	
Motortyp	motor type	KLORW 100L8-2	
Motorleistung	motor power	3,00 / 0,75	kW
Nennstrom	nominal current	7,15 / 2,96	A
Motordrehzahl	motor speed	2820 / 675	1/min
cos phi	cos phi	0,83 / 0,60	

Fahrwerk trolley			
Typ	type		
Traglast	working load		kg
Fahrgeschwindigkeit(en)	travelling speed(s)		m/min
IP Schutzart	IP protection		
Motortyp	motor type		
Motorleistung	motor power		kW
Nennstrom	nominal current		A
Motordrehzahl	motor speed		1/min
cos phi	cos phi		

Abmessungen in mm | dimensions in mm

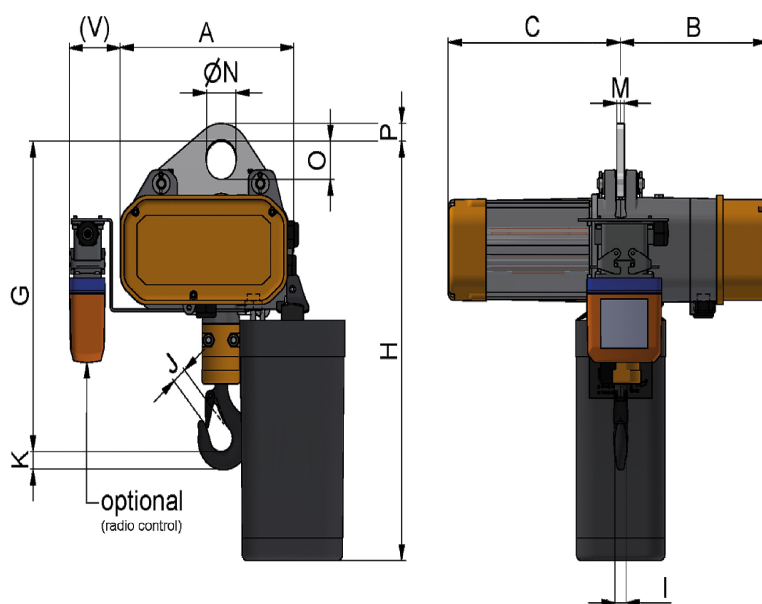

A	376
B	283
C	359
G	513
H	644
I	24
J	28
K	31
M	18
N	58
O	62
P	34