

DT 250

Operating instructions

05.2023

en-GB



Copyright

This document must not be distributed or reproduced, not even in part.

Copyright of this document remains with Jungheinrich PROFISHOP AG & Co. KG.

Haferweg 24

22769 Hamburg, Germany

For service enquiries and orders

Germany

0800 / 558833 - 4

service@jh-profishop.de

International

service@jungheinrichshop.com

Contents

A	About this manual	5
1	Scope and target group.....	5
2	Information and instructions.....	6
B	Security	7
1	Correct Use and Application.....	7
2	Duties of individuals.....	7
3	Safety information for specific operating phases.....	9
3.1	Transport.....	9
3.2	Operation.....	9
3.3	Maintenance.....	11
4	Conversions and modifications.....	11
5	Residual risks.....	12
C	Structure and function	13
1	Marking and labelling.....	14
1.1	Warning and information signs.....	14
1.2	Data plate.....	15
D	Technical Specifications	16
1	Dimensions.....	16
2	Performance data.....	16
E	Commissioning and transport	17
1	Using the Truck for the First Time.....	17
2	Transport.....	17
F	Operation	18
1	Checking the device before daily use.....	18
2	Raising the load.....	19
3	Moving the load.....	20
4	Lowering the load.....	21
5	Braking the device.....	21
6	Parking the device.....	21
G	Maintenance and repair	22
1	Faults and troubleshooting.....	22
2	Maintenance.....	24
2.1	Maintenance intervals.....	24
2.2	Consumables.....	25
3	Repairs.....	26
3.1	Safety tests to be performed at intervals and after unusual events.....	26
H	Shutdown, storage and disposal	27
1	Decommissioning.....	27

1.1	Shutting down the device.....	27
1.2	Returning the device to service after shutdown.....	27
2	Storage.....	27
2.1	Storing the device.....	27
3	Disposal.....	28
3.1	Decommissioning the device.....	28
3.2	Disposing of the device.....	28

A About this manual

These operating instructions describe the correct use of the products listed in the "Scope" chapter – see page 5. All Jungheinrich products are developed and produced according to the current state of the art. However, risks can arise in the case of incorrect use. Please observe the corresponding information and read through the operating instructions carefully. The operating instructions form part of the device and are valid for all specified device versions. The operating instructions describe the safe and correct use of the device in all operating phases.

→ Any technical questions should be directed to your authorised service partner.

The drum lifter described in these operating instructions is used for loading, unloading and moving drums.

1 Scope and target group

Scope

This document applies to the following device:

– DT 250

Target groups

For the purposes of these operating instructions the "owner" or "operator" is defined as any natural or legal person who either uses the described device himself or on whose behalf it is used. In special cases (e.g. rental), the owner is considered to be the person who is charged with the specified operational duties in accordance with existing contractual agreements between the owner and operator of the device.

Target group	Tasks
Owner	<ul style="list-style-type: none">– Keep these operating instructions accessible at the usage location of the device, including for later reference.– Ensure that the device is used correctly and only by trained and authorised personnel.– Instruct employees to read and observe these operating instructions and other applicable documentation, particularly the safety instructions and warnings – see page 7.– Observe additional device-specific provisions and regulations.
Operator	<ul style="list-style-type: none">– Read and observe these operating instructions and other applicable documentation, particularly the safety instructions and warnings see page 7.– Ensure that the device is used correctly and in accordance with the safety regulations.

Tab. 1: Owner and operator duties

2 Information and instructions

General information

→ Indicates additional information and explanations.

Structure of warnings

Warnings are used in this document to highlight potential causes of personal injury or material damage.

- Always read and observe these warnings.
- Follow all measures highlighted by the relevant warning.

The following warning levels are used to reflect the severity and probability of the relevant hazard:

⚠ DANGER!

Indicates an extremely dangerous situation. Failure to observe this warning can lead to serious, irreversible injuries or death.

⚠ WARNING!

Indicates an extremely dangerous situation. Failure to observe this warning can lead to serious, irreversible injuries or death.

⚠ CAUTION!

Indicates a dangerous situation. Failure to observe this warning can lead to minor or moderate injuries.

NOTICE

Indicates a risk of material damage. Failure to observe this warning can lead to material damage.

Structure of instructions

Instructions in this document are structured as follows:

Aim of the described activity

Requirements

- Prerequisites for activity

Tools and Material Required

- Tools and materials required for an activity (optional specification)

- Step
- Step
 - Sub-step

Result of action

B Security

The safety chapter provides important information on how to work safely with the described product. Failure to observe the specified measures can result in material damage and injuries, and potentially even death.

- Before commissioning and operating the device: Read the safety chapter thoroughly.
- Use the described device only as specified in this document.

1 Correct Use and Application

The device described in these operating instructions is designed for the safe transport of drums and is intended for private and commercial use.

Correct environmental conditions

The device will be permanently damaged if exposed to extreme environmental conditions.

- Only use the device under the permitted conditions – see page 16.
- Do not use the device in areas or environments with high levels of humidity.
- Do not use the device in areas or environments at risk of explosion or fire.
- Do not use the device in very dusty areas or environments.
- Do not use the device in outdoor areas.
- Do not use the device in corrosive areas or environments.
- Do not use the device in temperatures outside the permissible temperature range – see page 16.

Possible incorrect use

Inappropriate use of the device poses a risk of injury, will result in material damage and reduces the service life of the device.

The device is not suitable for the following applications:

- Transporting persons
- Transporting loads on slopes or inclines
- Transporting insufficiently secured loads
- Moving the device with electrical or mechanical aids

2 Duties of individuals

Duties of the owner

Incorrect preparation of the device can result in serious damage or injuries. The owner must:

- Ensure that the device is used as intended.
- Ensure that the device is in perfect technical condition.
- Ensure that all warnings and information signs are present on the device and in a language that the operator understands.
- Replace any damaged or missing warnings and information signs on the device.

- Ensure compliance with all regulations concerning accident prevention, safety and disposal as well as those regarding operation, maintenance and repairs.
- Provide suitable protective equipment for the operator.
- Make the operating instructions available at the usage location.
- Retain test reports for at least 2 years.

Duties of the operator

Incorrect operation of the device can result in serious damage or injuries. The operator must:

- Provide evidence of his or her ability to use the device.
- Provide evidence of his or her commissioning by the owner or their legal representative.
- Prevent unauthorised use of the device.
- Wear safety shoes or safety equipment in accordance with statutory and operational regulations when operating the device.
- Assume responsibility for the correct use of the device during operation.
- Independently take the device out of service and inform the relevant supervisor(s) in the case of damage to the device during operation.
- Before picking up the drum, make sure that the maximum permissible load capacity is not exceeded.

3 Safety information for specific operating phases

3.1 Transport

Transporting the device safely

Incorrectly secured transports can result in material damage and personal injury.

- Remove the load before transporting the device.
- Use lifting gear with sufficient capacity.
- Secure the HGV or trailer against rolling away before loading the device.
- Correctly secure the device to the lashing rings on the HGV or trailer.
- When jacking up, prevent slipping or tipping by means of wedges or wooden blocks.

3.2 Operation

Operating the device safely

Unsafe operation of the device can result in significant material damage and severe personal injury.

- Never transport persons on the load handler.
- Always look in the direction of travel.
- If the load is obscuring your view, travel backwards or instruct an additional person to proceed in front of the device as a lookout.
- Never place feet or other body parts in the vicinity of moving rollers.
- Adapt your travel speed to local conditions.
- In corners, at and in passageways and at blind spots, reduce your speed and be aware of the device dimensions.
- Do not travel on slopes or inclines.
- Maintain a sufficient stopping distance from trucks travelling in front.
- Adapt the stopping distance to the condition of the ground.
- Restrict (sudden) braking to hazardous situations.
- Avoid quick changes in direction.
- Do not overtake at blind spots.
- Do not lean or reach out of the operating area.
- Lower the load as far as possible for transport.
- If the load threatens to become unstable, stop and lower the load.

Requirements for travel paths and work areas

Failure to observe the specific environmental conditions can result in significant material damage and severe personal injury.

- Only travel on level surfaces that are designated as traffic routes.
- Maintain a sufficient safety clearance between the tiller and racks/walls.
- Do not travel on slopes or inclines unless expressly permitted in this document.
- Traffic route conditions have a significant influence on the stopping distance. Adjust the travel behaviour to the prevailing conditions.
- Visibility conditions have a significant influence on the travel path. Ensure that you have clear visibility.
- Keep unauthorised persons out of the work area.
- Always set down and store the load at the designated locations.
- Never deposit the load and device on traffic, escape or rescue routes or in front of passageways, roller shutter gates and doors.

Preventing injuries to third parties

A heightened accident risk exists for unauthorised persons in the hazardous area.

- Instruct unauthorised persons to leave the hazardous area.
- In the case of a potential risk to persons, issue a warning signal in a timely manner.
- If endangered persons fail to leave the hazardous area, stop the device immediately.

→ The hazardous area is classed as the area in which persons are exposed to a direct risk by the movements of the device or are endangered indirectly, e.g. due to a falling load.

Travelling onto lifts and loading bridges

A heightened risk of material damage and personal injury exists in lifts and on loading bridges.

- Before travelling onto lifts and loading bridges, ensure that they offer sufficient capacity for the individual weight of the device including the load and operator.
- Before travelling onto lifts and loading bridges, ensure that they are suitable and approved for such use by the owner.
- Travel load-first onto lifts and loading bridges and maintain a sufficient distance from the side walls.
- Park the device securely before any persons step into the left or onto the loading bridge.

Moving loads safely

An inadequately secured load poses a heightened risk of material damage and personal injury.

- Ensure that the load is in correct condition.
- Do not move loads unless they have been picked up safely and securely.
- If there is a risk of the load tipping: take appropriate protective measures.

Transporting liquids safely

When transporting liquids, the centre of gravity can vary according to the position of the device, which will significantly impact upon overall stability (e.g. in tanks).

- Avoid sudden/jerky braking or acceleration.
- Reduce the speed before and in corners.

3.3 Maintenance

Conducting maintenance work safely

Thorough and expert servicing is one of the most important prerequisites for safe operation of the device. Failure to perform regular maintenance can result in a malfunction of the device and poses a potential hazard to personnel and equipment.

- Perform maintenance and repair work in line with the specified maintenance intervals – see page 24.
- Maintenance and repair work must only be completed by specialist personnel with the requisite training.
- In the case of uncertainty, contact the manufacturer's customer service department.
- Use only original spare parts from the manufacturer.
- When repairing or replacing components, observe the device-specific settings.
- When replacing rollers, ensure that the device remains level (e.g. always replace left and right at the same time).
- Immediately after any maintenance work, complete all steps for returning the device to service – see page 9.
- Do not clean the device with flammable liquids.
- Before working on the hydraulic unit: Fully lower the load handler.
- Before working on the pump: Secure the return spring.

4 Conversions and modifications

Modifying the design and function of the device

Any conversions or changes to the design of the device which have not been approved by the manufacture can result in severe personal injury and significant material damage. All warranty and liability claims will be void.

If modifications are to be made, they require written permission from the manufacturer, an authorised representative or a legal successor. This includes, but is not limited to, the following actions:

- Changes affecting the capacity
- Changes affecting the stability
- Changes affecting the control function
- Changes affecting the visibility
- Addition of attachments.

Under no circumstances must the operating speed of the device be changed, not even with the manufacturer's approval.

5 Residual risks

Using consumables

Improper handling of consumables is hazardous to health, life and the environment.

- Use consumables in the correct manner and in accordance with the manufacturer's specifications.
- Work with consumables must only be performed by qualified specialist personnel.

C Structure and function

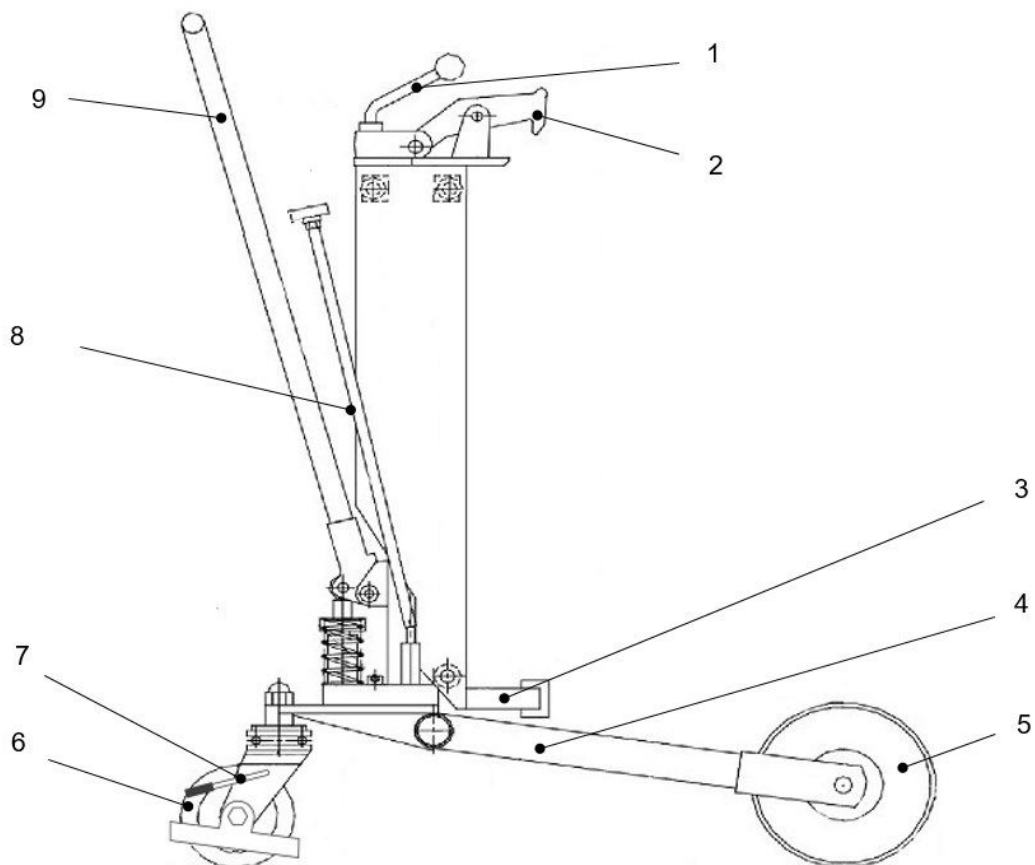

Fig. 1: Assemblies and functional description

Item	Description	Function
1	Hand lever	Operates the hook.
2	Hook	Carries the load.
3	Support	Secures the drum.
4	Chassis	Moves the unit.
5	Roller	
6	Swivel castor	
7	Parking brake	Used to park the device securely.
8	Lowering linkage with rotary knob	Lowers the drum.
9	Tiller	Controls the device.

1 Marking and labelling

1.1 Warning and information signs

Locations of the warning and information signs



Item	Description
1	Logo (both sides)
2	Data plate
3	Q _{max} XXXX kg
4	Information sign: "Risk of trapping"
5	Jungheinrich PROFISHOP

1.2 Data plate

Jungheinrich PROFISHOP AG & Co. KG
 Haferweg 24, 22769 Hamburg, GERMANY
 Hersteller / Manufacturer

9 Produktbezeichnung / Product Type Artikelnummer / Item Number 2

8 Typ / Type Option / Option 3

7 Seriennummer / Serial Number Baujahr / Year of Manufacture 4

6 Nenntragfähigkeit / Rated Capacity Leergewicht / Weight 5

CE UK CA Made in

Fig. 2: Data plate (schematic)

Item	Information
1	Name and address of manufacturer
2	Article number
3	Option
4	Year of manufacture
5	Net weight
6	Rated capacity
7	Serial number
8	Type
9	Product designation

D Technical Specifications

1 Dimensions

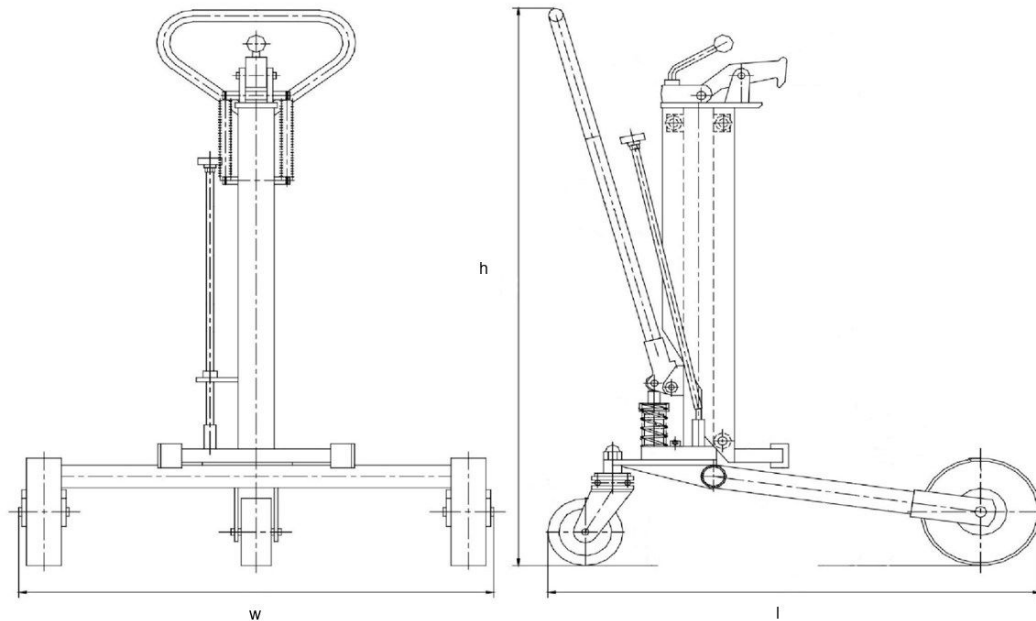

Fig. 3: Device dimensions (schematic)

2 Performance data

Description	Value	Unit
Identification		
Manufacturer's type designation	DT 250	–
Capacity (Q)	250	kg
Basic dimensions		
Height (h)	1050	mm
Width (w)	800	mm
Length (l)	820	mm
Weight	45	kg
Max. drum diameter	572	mm

Correct environmental conditions

Condition	Value
Application area	Indoor application
Permitted ambient temperature	+5°C to +40°C
Minimum illumination	50 Lx

E Commissioning and transport

1 Using the Truck for the First Time

Preparing for commissioning

- Verify that the warning and information signs are present and undamaged. Replace any damaged or missing signs.
- Check all supplied components for transport damage.
- Check the functionality of the actuators, rollers, wheel axles and scissor lift axles.
- Immediately notify the carrier of any transport damage or missing components.

2 Transport

⚠ CAUTION!

Inadequately secured transport!

Risk of material damage and personal injury due to unsecured loads.

- ▶ The device must be sufficiently secured when transported on an HGV or trailer.
- ▶ Use the lashing rings on the HGV or trailer.
- ▶ The device must only be loaded by specially trained personnel while observing the applicable regulations.

⚠ WARNING!

Inadequately secured load!

Risk of material damage and personal injury due to falling loads.

- ▶ Always use cranes and lifting gear with sufficient capacity.
- ▶ Attach lifting gear only to the designated attachment points.
- ▶ Ensure that there are no persons in the area under the suspended load.
- ▶ Instruct all persons to leave the hazardous area during crane loading.

F Operation

⚠ CAUTION!

Collisions with persons in the vicinity!

Risk of personal injury.

- ▶ Before moving the device, raising or lowering the load, instruct persons to leave the hazardous area.
 - ▶ In the case of a potential risk to persons, issue a warning signal in a timely manner.
 - ▶ If endangered persons fail to leave the hazardous area, stop the device immediately.
-

1 Checking the device before daily use

Regular inspection allows faults or malfunctions to be recognised at an early stage and rectified promptly. This increases the service life of the product and helps to ensure safe operation.

Checking the device for damage and defects before start-up at the beginning of a shift

- Remove any loads from the device and move the load handler to its lowest position.
- Visually inspect all assemblies for deformation or cracks.
- Check the lift mechanism for correct function and ease of movement. Look out for any unusual noises and blockages.
- Check the load handler and carriage for wear and damage.
- Check the hydraulic system for leaks.
- Check the rollers for correct function and ease of movement.
- Check the hydraulic oil level and top up if necessary.
- Check the vertical elongation of the lift mechanism.
- Verify that all screws and nuts are securely fastened.
- Verify that all signs and warnings are present and legible.
- Immediately notify the relevant supervisor(s) of any damage or defects on the device or attachments.
- Take any devices with damaged or defective safety-relevant components out of service and repair them before next use.
- Check the hook for wear and repair if necessary.

2 Raising the load

⚠ WARNING!

Inadequately secured load!

Risk of material damage and personal injury due to falling loads.

- ▶ Do not move loads unless they have been picked up safely and securely.
 - ▶ If there is a risk of the load tipping: take appropriate protective measures.
-

NOTICE

Exceeding the permitted load capacity!

Risk of damage to the device due to excessive loads.

- ▶ Note the permissible maximum capacity.
-

Raising the drum

- Position the drum between the two support arms.
- Apply the parking brake on the swivel castor.
- Move the tiller up and down and at the same time apply the hook securely to the upper edge of the drum.
- Continue to move the tiller up and down until the desired height is reached (max. lift height 200 mm).

The drum is raised.

3 Moving the load

⚠ WARNING!

Unsecurely picked up load!

Risk of personal injury and material damage due to sudden tipping of the load.

- ▶ Ensure that the load is in correct condition.
 - ▶ Only move loads that have been picked up safely and securely.
-

⚠ CAUTION!

Unintentional lowering of the load!

Risk of personal injury due to crushing.

- ▶ Do not place any part of your body between the raised load and the ground.
-

Moving the drum

Requirements

- Drum is in the lowest position.
- Parking brake is released.
- Move the tiller to the side to steer the device to the left or right.

The device moves in the desired direction.

4 Lowering the load

⚠ CAUTION!

Lowering heavy loads!

Risk of personal injury due to crushing.

- ▶ Always lower the load slowly and carefully.
- ▶ Do not place any part of your body between the raised load and the ground.
- ▶ Wear safety shoes.

NOTICE

Increased impact load!

Risk of device damage and malfunction due to excessively fast lowering of the load.

- ▶ Always lower the load slowly and carefully.

- If the device is to be moved after depositing the load, ensure that there is sufficient room for manoeuvring.

Lowering the drum

- Turn the knob on the lowering linkage to the left and slowly lower the drum.

- Due to the risk of damage to the drum or the drum lifter, turn the knob on the lowering boom carefully to the left.

The drum has been lowered.

5 Braking the device

Braking the device slowly

- Move the tiller in the opposite direction to the travel direction until the device comes to a stop.

The device has been stopped.

6 Parking the device

Parking the device securely

- Position the device on a smooth, level surface.
- Fully lower the load handler.
- Fold up the tiller so that it doesn't hinder other operations.
- Apply the parking brake on the swivel castor.

The device is parked securely.

G Maintenance and repair

1 Faults and troubleshooting

- In the case of a device fault, carry out the following troubleshooting measures.
- If you encounter problems when carrying out the measures or if they fail to rectify the problem, contact the manufacturer's customer service department.

⚠ CAUTION!

Incorrect maintenance!

Risk of material damage and personal injury due to failure of important components.

- ▶ Use only original spare parts from the manufacturer.
- ▶ Maintenance and repair work must only be completed by specialist personnel with the requisite training.
- ▶ When replacing rollers, ensure that the device remains level (e.g. always replace left and right at the same time).
- ▶ Always observe the device-specific settings when carrying out repairs or replacing components.

Fault table

Fault	Possible cause	Fault rectification
Load handler not lifting even though the hydraulic pump is working correctly.	Air in the hydraulic system.	Bleed the hydraulic system.
	Hydraulic pump faulty.	Check the hydraulic pump and replace if necessary.
	Load is too heavy (overload valve actuated).	Reduce the load.
	Control lever is not set correctly.	Set the control lever or piston rod.
	Lowering valve no longer closes or valve body is leaking due to oil contamination.	Clean the lowering valve or piston rod and replace if necessary.
	Oil level in hydraulic reservoir too low.	Lower the load handler and top up the hydraulic oil.
	Viscosity of hydraulic oil is too high.	Use suitable hydraulic oil.
	Lowering valve is not coordinated with control lever.	Adjust the piston rod nut.
Load handler does not reach the top position.	Oil level in hydraulic reservoir too low.	Lower the load handler and top up the hydraulic oil.

Fault	Possible cause	Fault rectification
Raised load is lowered only slowly or not at all.	Ambient temperature too low, hydraulic oil too viscous.	Move to area with higher ambient temperature.
	Hydraulic cylinder is damaged or deformed.	Repair components or have them replaced.
Raised load handler lowers automatically.	Hydraulic unit is leaking.	Check the hydraulic unit and replace if necessary.
	Lowering valve no longer closes or valve body is leaking due to oil contamination.	Adjust, clean or replace the valve.

2 Maintenance

⚠ CAUTION!

Uncontrolled movement of the device!

Risk of personal injury and material damage due to sudden movements of the device.

- ▶ Park the device securely when not in use and before maintenance work.
 - ▶ If possible, switch off the device.
 - ▶ If possible, use the parking brake.
-

⚠ CAUTION!

Safety equipment rendered ineffective!

Risk of personal injury and material damage due to ineffective safety equipment.

- ▶ Under no circumstances must safety equipment (e.g. emergency disconnect switch) be rendered ineffective.
 - ▶ Repairs must only be carried out by qualified specialists.
-

2.1 Maintenance intervals

Requirements

- The device is used in single-shift operation.
- The device is used under normal operating conditions – see page 7.
- Maintain the device at the specified intervals.
- If the device is operated in very dusty conditions, subjected to extreme temperature fluctuations or used in multi-shift operation, the intervals must be reduced accordingly.

Maintenance interval	Maintenance
Daily.	Check the device before use – see page 18
After all cleaning and repair work.	<ul style="list-style-type: none"> – Lubricate the device at the designated points – see page 25. – Check and bleed the hydraulic system and/or top up oil.
After the first 100 operating hours.	<ul style="list-style-type: none"> – Re-tighten wheel nuts and bolts. – Check the hydraulic system for leaks. – Check that retaining rings, locking and cotter pins are in place.
Monthly.	<ul style="list-style-type: none"> – Lubricate all bearings and shafts with long-life lubricant. – Remove dirt and foreign bodies.
Every 3 months.	Check the setting of the bleed valve.
Every 4000 operating hours or at least every 6 months.	<ul style="list-style-type: none"> – Check the hydraulic oil and replace if necessary (more frequently if the oil is very dark, contaminated or flocculating). – Check all parts of the device for wear and replace faulty parts.
Annually or after unusual events.	Have safety checks performed at regular intervals and following any unusual events – see page 26.

2.2 Consumables

Lubricants

Lubricants		Value	Unit
Hydraulic oil	Oil type	ISO VG 46	-
	Viscosity	46	cSt at 40 °C
	Refill quantity	0.3	Litres
Multi-purpose lubricant		MoS2 anti-friction coating	-

3 Repairs

3.1 Safety tests to be performed at intervals and after unusual events

→ Always perform safety checks in accordance with national regulations. These may deviate from the steps listed below.

Requirements

- The inspecting person is qualified to conduct the following check.
 - The inspecting person is independent and unbiased (from an operational and business perspective) and assesses the device purely in terms of its safety.
 - The inspecting person possesses sufficient knowledge and experience to assess the condition of the device and the effectiveness of the safety equipment based on the rules of technology and the principles for testing the described device.
-
- Inspect the technical condition of the device with regard to accident safety.
 - Thoroughly check the device for damage.
 - Produce a written test report and retain it for at least 2 years. Responsibility for the test report rests with the owner.
 - Rectify any identified defects before next using the device.
 - Following a successful inspection, attach an inspection plaque to the device in a visible location.

H Shutdown, storage and disposal

1 Decommissioning

1.1 Shutting down the device

- Thoroughly clean the device.
- Check the hydraulic oil level and top up if necessary.
- Apply a thin layer of oil or grease to any non-painted mechanical components.
- Lubricate the device.

1.2 Returning the device to service after shutdown

- Thoroughly clean the device.
- Lubricate the device.
- Check the hydraulic oil for condensation water and replace the oil if necessary.
- Start up the device.
- Perform a complete function check immediately after start-up.

2 Storage

2.1 Storing the device

NOTICE

Incorrect storage!

Risk of material damage.

- ▶ Always store the device in a dry and frost-free environment.
 - ▶ Jack up the device so that the rollers can spin freely.
-

Storing the device

Requirements

- Device is being taken out of service for more than 2 months (e.g. for operational reasons).
- Device has been prepared for storage as described, see page 27.
- Protect the device against dust and corrosion, e.g. using a tarpaulin.
- Before storing the device for longer than 6 months, discuss necessary additional measures with the manufacturer's customer service department.

3 Disposal

3.1 Decommissioning the device

- Observe the applicable regulations in the country of use when decommissioning the device.

3.2 Disposing of the device

- Observe the country-specific regulations regarding disposal of the device and consumables.